

■ Description of the model designation

● HFK3H type

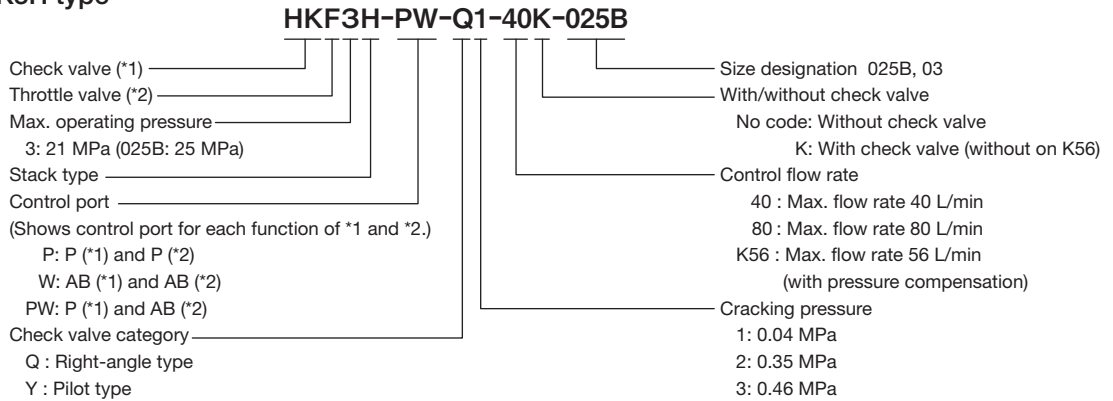

● HFG3H type

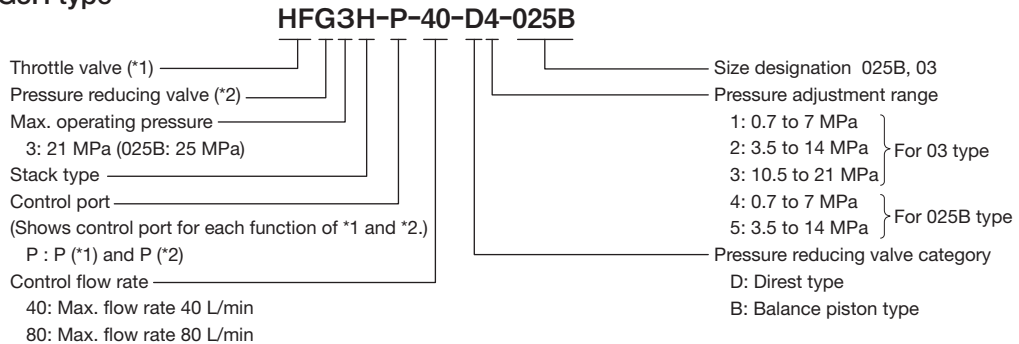

● HKG3H type

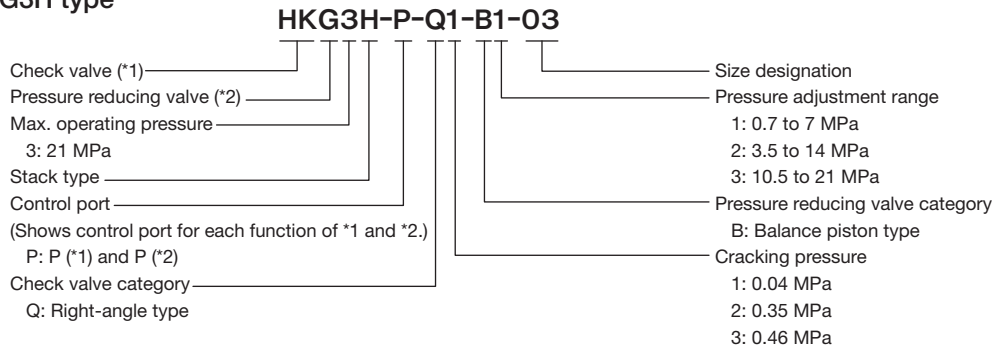

● HGF3H type

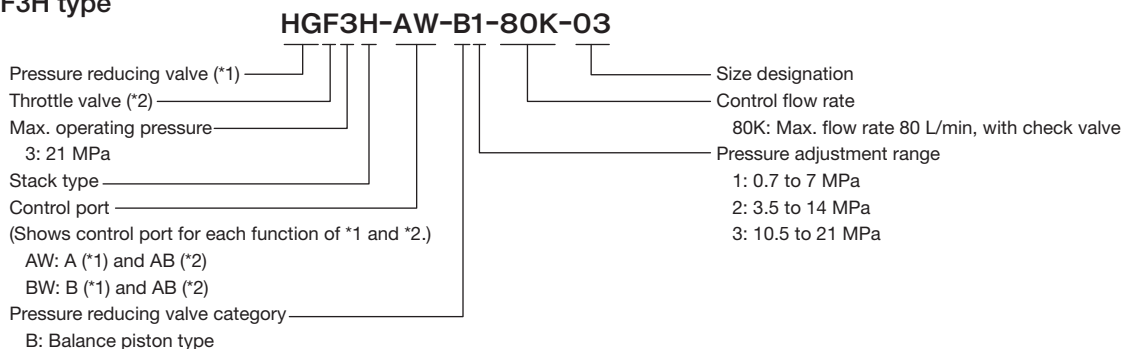

■ Specifications

Size 025

Type	Symbol	Max. operating pressure (MPa)	Flow rate adjustment range (L/min)	Cracking pressure (MPa)	Pressure adjustment range (MPa)
HKF3H-P-Q*-40-025B		25	0.5 to 40	* Symbol 1: 0.04 2: 0.35 3: 0.46	—
HFG3H-P-40-D*-025B				—	* Symbol 4: 0.7 to 7 5: 3.5 to 14
HKF3H-W-Y*-40K-025B				* Symbol 1: 0.04 2: 0.35	—
HKF3H-PW-Q*-40K-025B				* Symbol 1: 0.04 2: 0.35 3: 0.46	—

Size 03

Type	Symbol	Max. operating pressure (MPa)	Flow rate adjustment range (L/min)	Cracking pressure (MPa)	Pressure adjustment range (MPa)	
HKF3H-P-Q*-80-03		21	0.5 to 80	* Symbol 1: 0.04 2: 0.35 3: 0.46	—	
HKF3H-P-Q*-K56-03			Max. control flow rate 56			
HKG3H-P-Q*-B*-03			0.5 to 80	* Symbol 1: 0.04 2: 0.35	—	* Symbol 1: 0.7 to 7 2: 3.5 to 14 3: 10.5 to 21
HFG3H-P-80-B*-03						
HKF3H-W-Y*-80K-03						
HKF3H-PW-Q*-80K-03						
HGF3H-AW-B*-80K-03			—	* Symbol 1: 0.7 to 7 2: 3.5 to 14 3: 10.5 to 21		
HGF3H-BW-B*-80K-03						

D

HY-TEGRA SYSTEM

■ Outside dimensions

HKF3H-P-Q*-40-025B

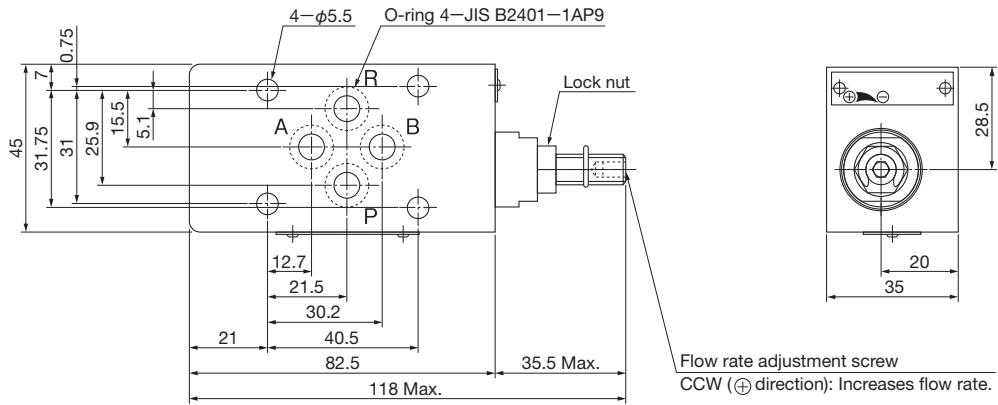

Mass: 0.9kg

HFG3H-P-40-D*-025B

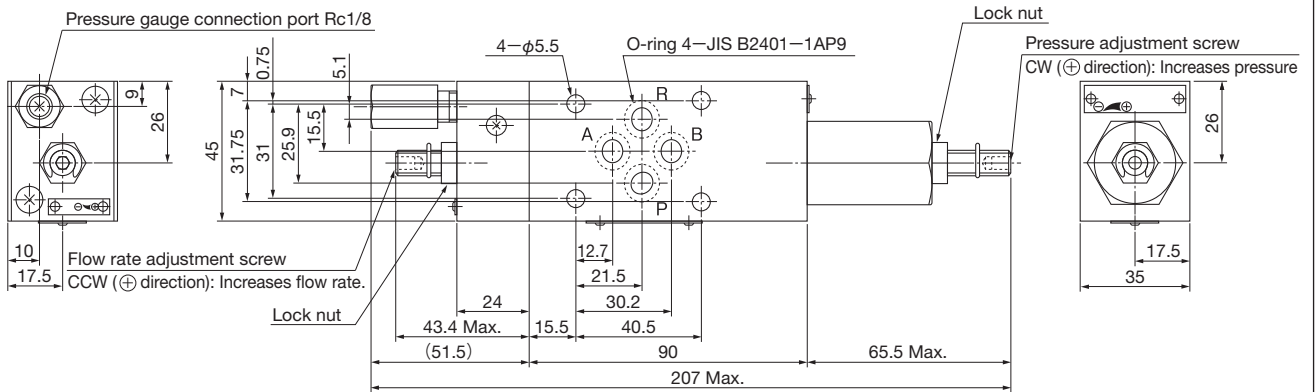

Mass: 1.36kg

HKF3H-W-Y*-40K-025B

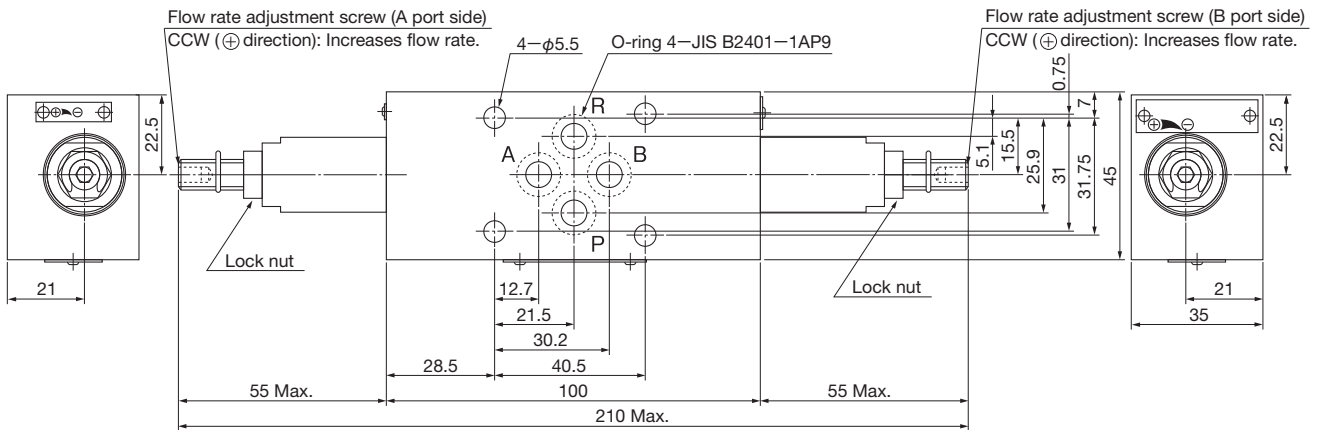

Mass: 1.3kg

■ Outside dimensions

HKF3H-PW-Q*-40K-025B

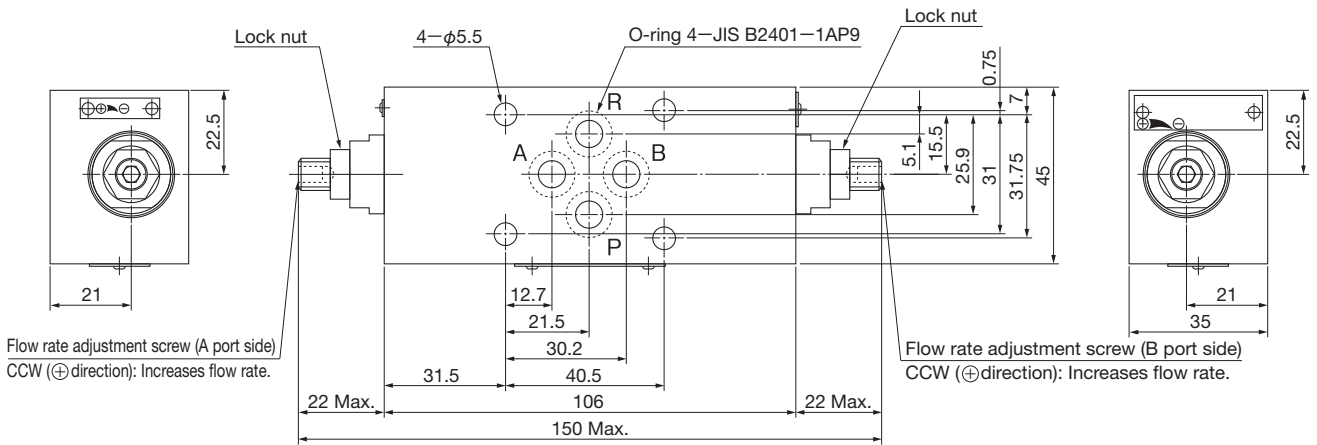

Mass: 1.16kg

HKF3H-P-Q*-80-03

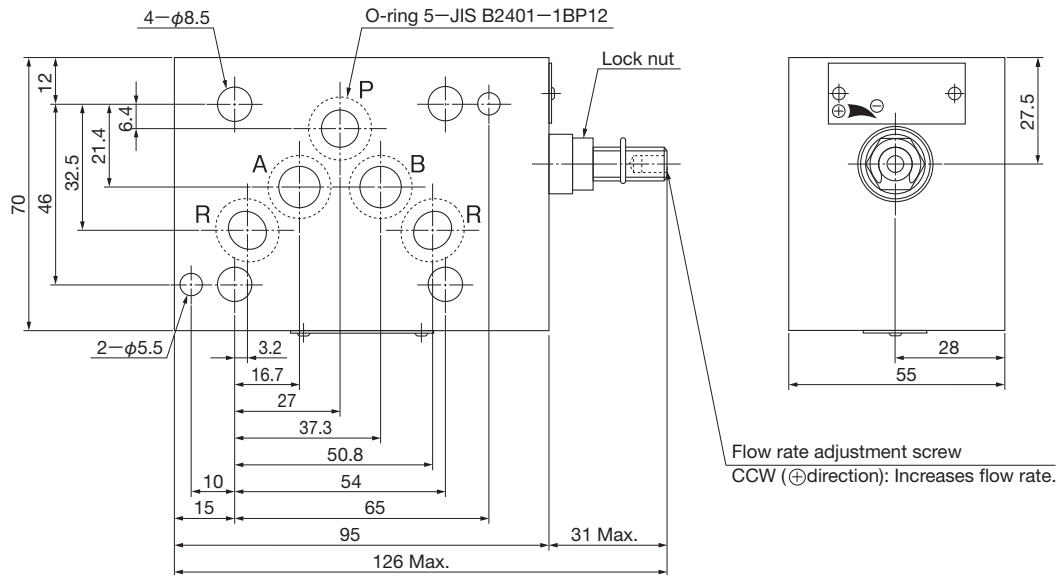

Mass: 2.5kg

HKF3H-P-Q*-K56-03

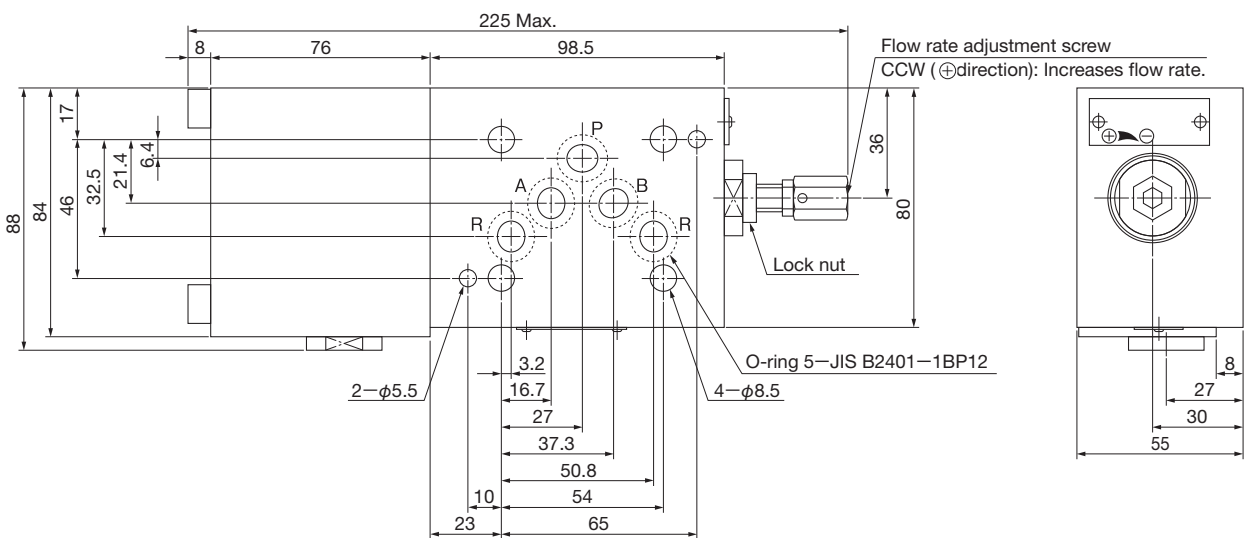

Mass: 5kg

Outside dimensions

HKG3H-P-Q*-B*-03

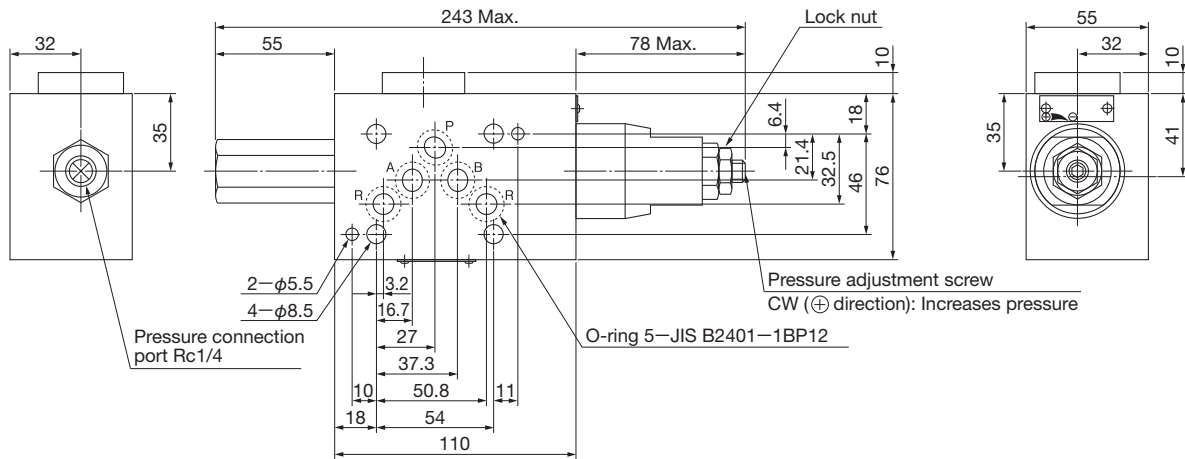

Mass: 3.8kg

HFG3H-P-80-B*-03

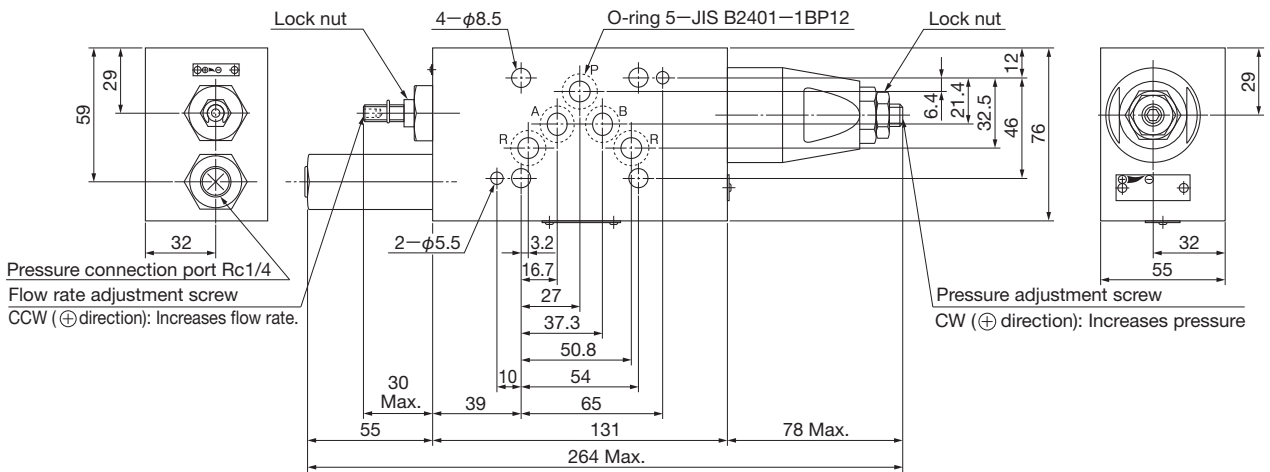

Mass: 4.4kg

HKF3H-W-Y*-80K-03

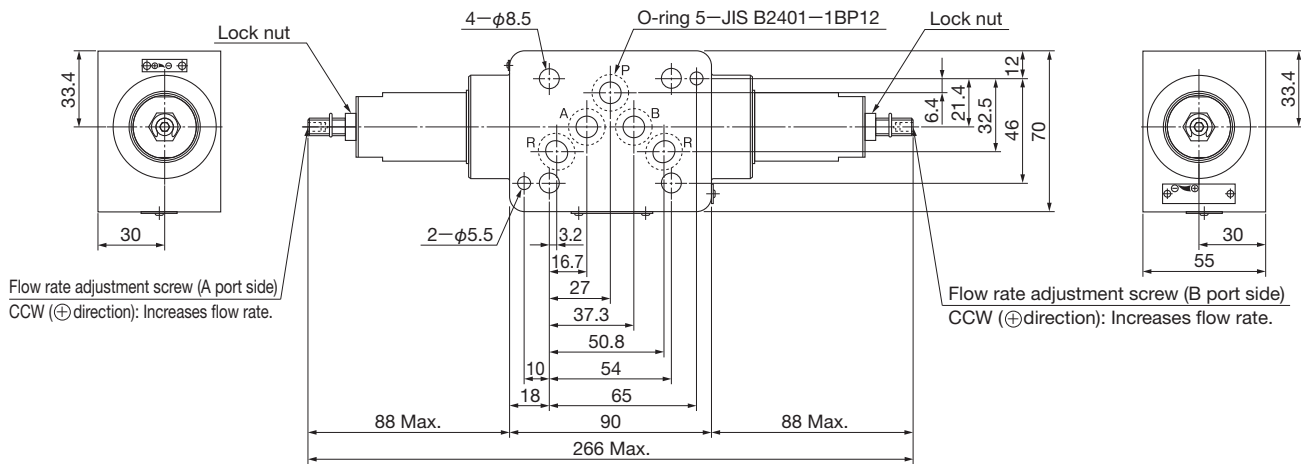

Mass: 3.1kg

■ Outside dimensions

HKF3H-PW-Q*-80K-03

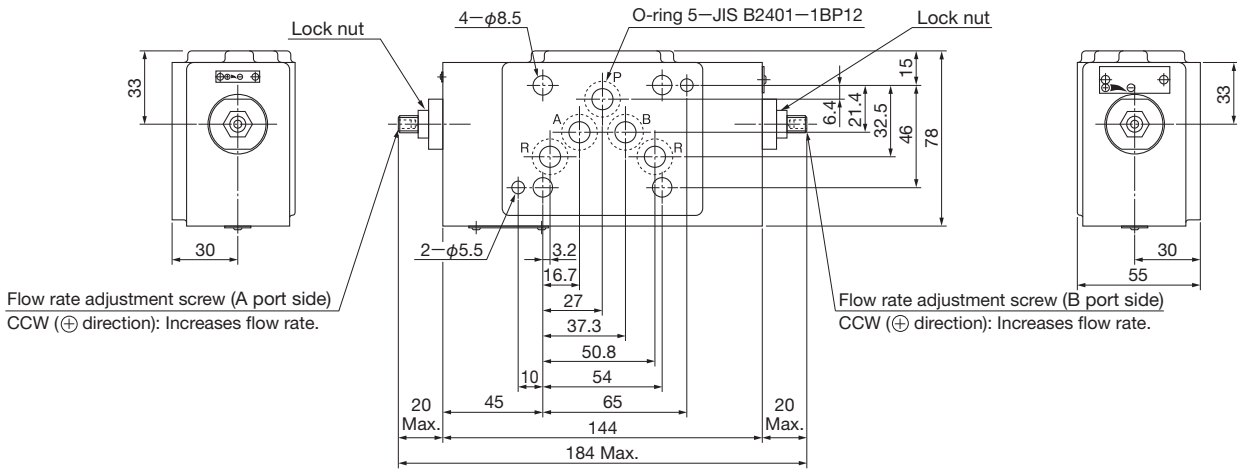

Mass: 4.8kg

HGF3H-AW-B*-80K-03

HGF3H-BW-B*-80K-03

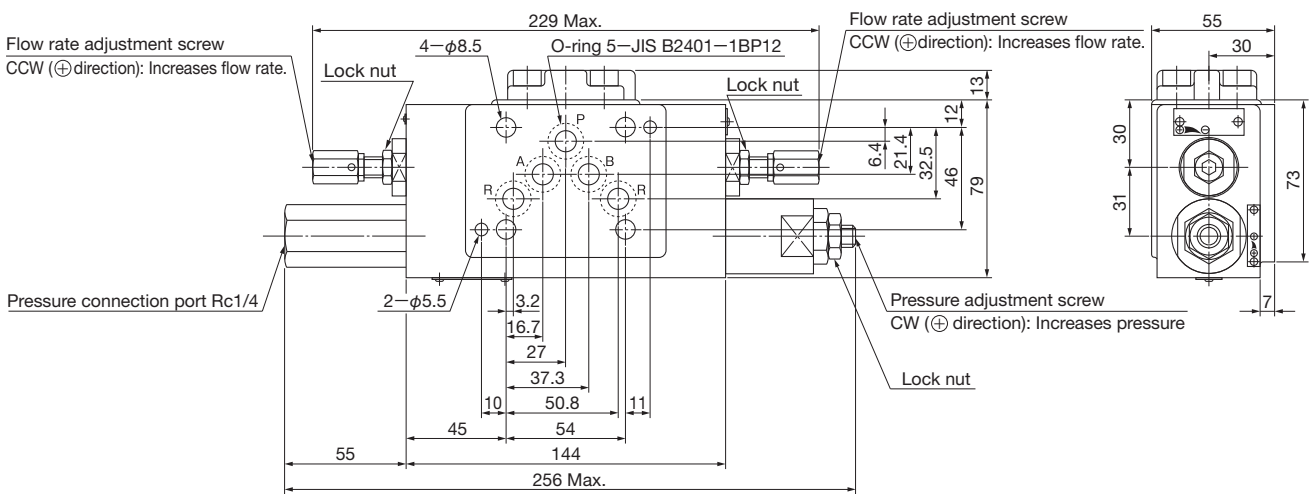

Mass: 4.5kg



HY-TEGRA SYSTEM