

# CONTROL AMPLIFIER FOR EHD3-06-F (WITH INTERNAL FEEDBACK)

ECAD-D1FB-\*

## Features

This control amplifier drives current-controlled type directional and flow control valves (EHD3-06-F).

The control circuit power supply is stabilized and an operational amplifier is used for the control circuit so that the control amplifier ensures stable operation regardless of variations in the power supply voltage and load. In addition, the differential transformer built into the valve provides feedback control to achieve accurate control.

- The chassis is not connected to the ground of the internal control power supply. To connect the chassis to the internal control power supply ground, connect terminal No. 4 to terminal No. 9.
- If the SOL connection terminal is disconnected with the power on, a surge voltage is generated and it may degrade the solenoid insulation.

## Specifications

Model	ECAD-D1FB-A	ECAD-D1FB-B
Power supply voltage	AC100/110 V 50/60Hz	AC200/220 V 50/60Hz
Permissible voltage variation range	±10%	
Input voltage	DC0 to 10 V	
Max. gain	300 mA / 5 V	
Input impedance	8 KΩ	
Rated output current	300 mA	
Variable resistor for setting	2 kΩ (when an external setting variable resistor is used)	
Operating temperature range	0 to 50°C	
Max. power consumption	16 VA	
Applicable valve	EHD3-06-F	

## Outside dimensions

ECAD-D1FB-\*

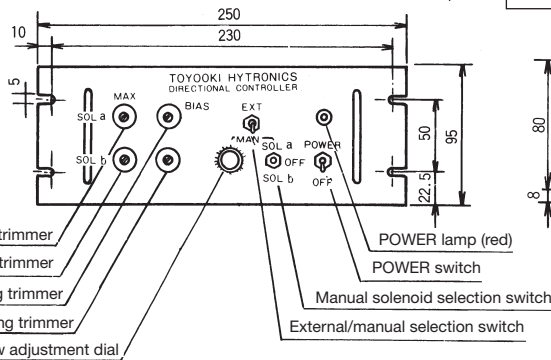
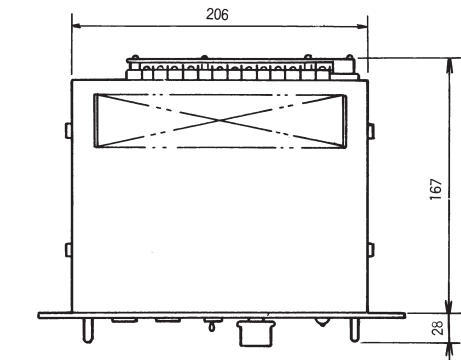

- SOLa max. flow adjusting trimmer
- SOLb max. flow adjusting trimmer
- Bias adjusting trimmer
- Bias adjusting trimmer
- Manual flow adjustment dial
- POWER lamp (red)
- POWER switch
- Manual solenoid selection switch
- External/manual selection switch

## Terminal functions

Terminal No.	Descriptions	Terminal No.	Descriptions
1	Power supply input	13	Output signal +10V
2	1 to 2: AC100 V (AC200 V)	14	↑ -10V
3	1 to 3: AC110 V (AC220 V)	15	Input/output of differential transformer 15→F 16→A 17→B 18→C 19→D 20→E
4	Frame ground	16	
5	Output to valve SOLa	17	
6		18	
7	Output to valve SOLb	19	
8		20	
9	Shield	21	Output of differential transformer displacement COM
10	Input signal COM	22	↑ SIG
11	↑ SOLa IN	23	Spare
12	↑ SOLb IN	24	

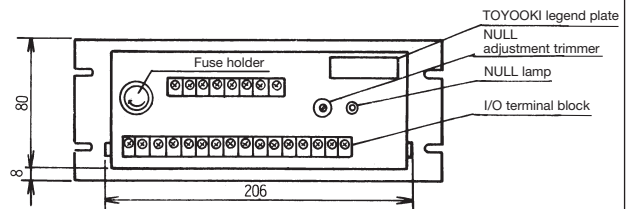

## Terminal connection

