

HYDRAULIC CYLINDER FOR 7 MPa (DOUBLE ACTING DOUBLE ROD TYPE) (HC1-W) $\phi 40$ to $\phi 100$

Specifications

Max. operating pressure (MPa)	7
Min. working pressure (MPa)	0.45 or less
Operating speed range (mm/s)	8 to 300
Operating temperature range (°C)	-15 to 80

Permissible stroke error

Stroke	100 or less	100 to 250	250 to 630	630 to 1,000	1,000 to 1,600
Permissible error	+0.8 0	+1.0 0	+1.25 0	+1.4 0	+1.6 0

Outside dimensions

LB (Foot mount type)

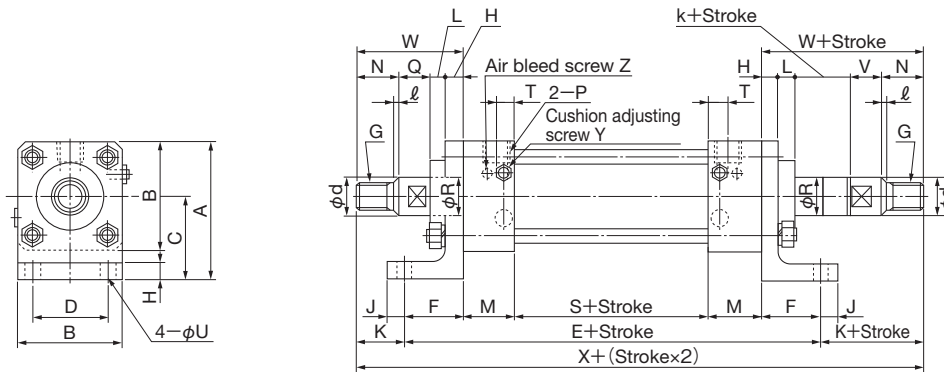

(Unit: mm)

Model	Symbol	A	B	C	D	E	F	G	H	J	K	L	M	N	ℓ	P	Q	R	d(h7)	S	T	U	V	k	W	X	Y	Z
HC1-W*-40x*-LB		80	60	50	44	196	38	M16×1.5	10	10	33	12	33	25	3	Rc $\frac{1}{4}$	24	20	20	54	13	9	22	2	71	262	M 8	M6
HC1-W*-50x*-LB		97.5	75	60	55	226	44	M20×1.5	12	11	38	14	38	30	3	Rc $\frac{3}{8}$	26	25	24	62	14	11	24	2	82	302	M 8	M6
HC1-W*-63x*-LB		115	90	70	65	268	51	M24×2	14	13	40	14	45	35	4	Rc $\frac{1}{2}$	28	31.5	30	76	16	13	25	3	91	348	M 8	M6
HC1-W*-80x*-LB		142	114	85	84	296	56	M30×2	14	15	43	16	48	40	4	Rc $\frac{3}{4}$	29	40	38	88	20	15	26	3	99	382	M12	M6
HC1-W*-100x*-LB		160	130	95	100	324	66	M42×3	16	17	53	17	50	55	6	Rc $\frac{3}{4}$	31	50	48	92	20	17	28	3	119	430	M12	M6

FA (Rod side flange mount type)

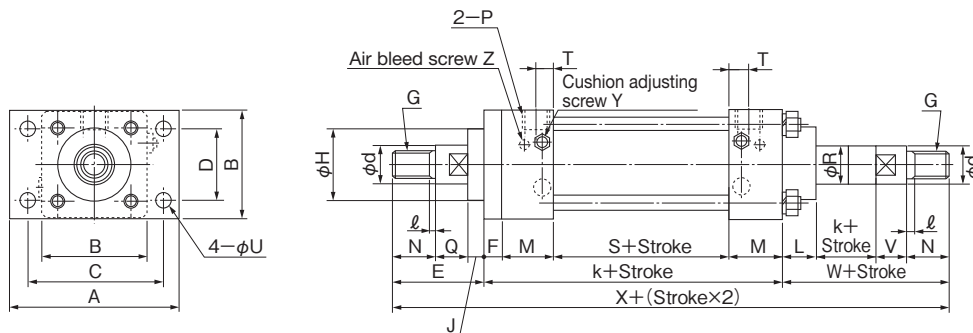

(Unit: mm)

Model	Symbol	A	B	C	D	E	F	G	H	J	K	L	M	N	ℓ	P	Q	R	d(h7)	S	T	U	V	k	W	X	Y	Z
HC1-W*-40x*-FA		95	60	77	44	61	10	M16×1.5	40	12	130	22	33	25	3	Rc $\frac{1}{4}$	24	20	20	54	13	9	22	2	71	262	M 8	M6
HC1-W*-50x*-FA		117	75	97	55	70	12	M20×1.5	50	14	150	26	38	30	3	Rc $\frac{3}{8}$	26	25	24	62	14	11	24	2	82	302	M 8	M6
HC1-W*-63x*-FA		142	90	116	65	77	14	M24×2	60	14	180	28	45	35	4	Rc $\frac{1}{2}$	28	31.5	30	76	16	13	25	3	91	348	M 8	M6
HC1-W*-80x*-FA		175	114	145	84	83	16	M30×2	70	14	200	30	48	40	4	Rc $\frac{3}{4}$	29	40	38	88	20	15	26	3	99	382	M12	M6
HC1-W*-100x*-FA		195	130	165	100	101	18	M42×3	80	15	210	33	50	55	6	Rc $\frac{3}{4}$	31	50	48	92	20	17	28	3	119	430	M12	M6

Description of the model designation

HC1-WD-40×100-LB-(A)

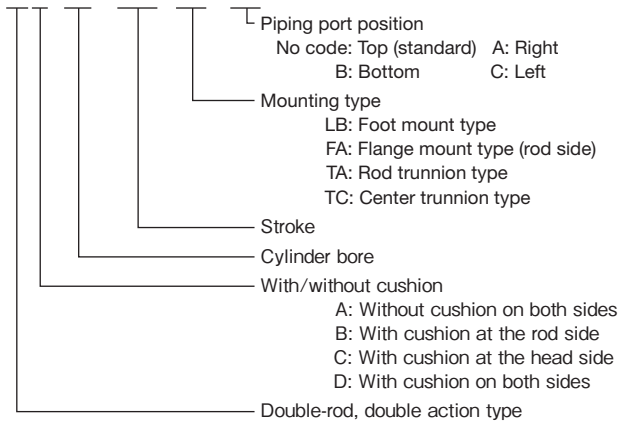

■ Outside dimensions

TA (Rod trunnion type)

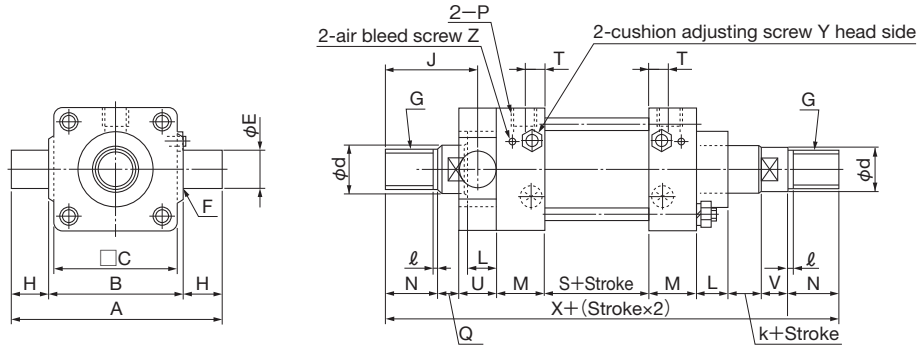

(Unit: mm)

Model	Symbol	A	B	C	D	E	F	G	H	J	L	M	N	ℓ	P	Q	R	d(h7)	S	T	U	V	k	X	Y	Z
HC1-W*-40x*-TA		109	69	60	67	20	2	M16×1.5	20	60	22	33	25	3	Rc ¹ / ₄	24	20	20 ¹⁸	54	13	22	22	2	262	M 8	M6
HC1-W*-50x*-TA		135	85	75	81	25	2.5	M20×1.5	25	68	26	38	30	3	Rc ³ / ₈	26	25	24	62	14	28	24	2	302	M 8	M6
HC1-W*-63x*-TA		160	98	90	94	31.5	2.5	M24×2	31	74	28	45	35	4	Rc ¹ / ₂	28	31.5	30	76	16	34	25	3	348	M 8	M6
HC1-W*-80x*-TA		180	118	114	116	31.5	2.5	M30×2	31	82	30	48	40	4	Rc ³ / ₄	29	40	38	88	20	34	26	3	382	M12	M6
HC1-W*-100x*-TA		225	145	130	141	40	3	M42×3	40	97	33	50	55	6	Rc ³ / ₄	31	50	48	92	20	44	28	3	430	M12	M6

TC (Center trunnion type)

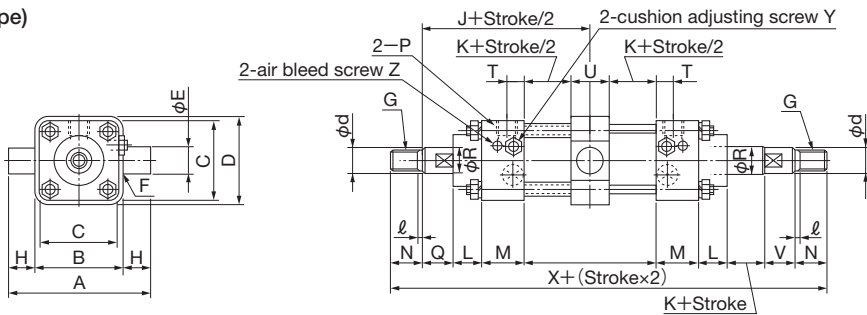

(Unit: mm)

Model	Symbol	A	B	C	D	E	F	G	H	J	K	L	M	N	ℓ	P	Q	R	d(h7)	S	T	U	V	k	X	Y	Z
HC1-W*-40x*-TC		109	69	60	67	20	2	M16×1.5	20	106	12	22	33	25	3	Rc ¹ / ₄	24	20	20	54	13	30	22	2	262	M 8	M6
HC1-W*-50x*-TC		135	85	75	81	25	2.5	M20×1.5	25	121	12	26	38	30	3	Rc ³ / ₈	26	25	24	62	14	38	24	2	302	M 8	M6
HC1-W*-63x*-TC		160	98	90	94	31.5	2.5	M24×2	31	139	16	28	45	35	4	Rc ¹ / ₂	28	31.5	30	76	16	44	25	3	348	M 8	M6
HC1-W*-80x*-TC		180	118	114	116	31.5	2.5	M30×2	31	151	20	30	48	40	4	Rc ³ / ₄	29	40	38	88	20	48	26	3	382	M12	M6
HC1-W*-100x*-TC		225	145	130	141	40	3	M42×3	40	160	17	33	50	55	6	Rc ³ / ₄	31	50	48	92	20	58	28	3	430	M12	M6

Knuckle bracket · HC-A1-*

Knuckle bracket Diameter

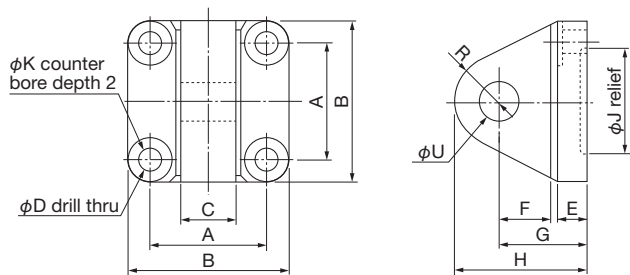

(Unit: mm)

Model	Symbol													
	A	B	C	D	E	F	G	H	J	K	R	U _(H8)	TA-A _{-X*}	
HC-A1-40	44	60	19	9	12	22	37	57	40	19	20	16	8×25	
HC-A1-50	55	75	27	11	14	24	41	63	50	23	22	18	10×30	
HC-A1-63	65	90	30	13	16	27	46	71	60	28	25	20	12×35	
HC-A1-80	84	114	36	15	20	35	60	90	70	31	30	25	14×35	
HC-A1-100	100	130	48	17	24	50	80	120	80	34	40	35	16×40	

Knuckle · HC-B2-*

Knuckle Diameter

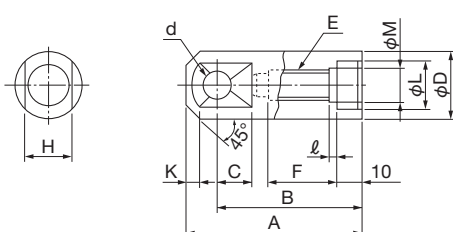

(Unit: mm)

Model	Symbol											
	A	B	C	D	d _(H8)	E	F	H	K	L _(F8)	M	ℓ
HC-B2-40	75	60	16	28	13	M16×1.5	28	22	5	20	16.2	4
HC-B2-50	80	63	17	32	16	M20×1.5	33	24	5	24	20.3	4
HC-B2-63	85	67	20	38	16	M24×2	38	27	8	30	24.4	5
HC-B2-80	105	85	25	46	22	M30×2	43	32	10	38	30.5	5
HC-B2-100	140	113	32	56	30	M42×3	60	41	14	48	43	7

■ Outside dimensions

Bracket pin · HC-C1-*

└─ Diameter
└─ Bracket pin

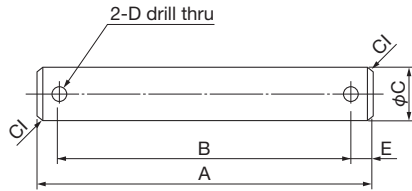

(Unit: mm)

Model	Symbol				
	A	B	C (φ)	D	E
HC-C1-40	78	70	16	2.5	4
HC-C1-50	95	86	18	2.5	4.5
HC-C1-63	112	102	20	2.5	5
HC-C1-80	140	128	25	3	6
HC-C1-100	160	148	35	4	6

Locknut · HC-N1-*

└─ Diameter
└─ Locknut

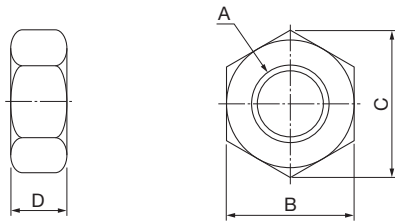

(Unit: mm)

Model	Symbol			
	A	B	C (Approx.)	D
HC-N1-40	M16×1.5	24	27.7	10
HC-N1-50	M20×1.5	30	34.6	12
HC-N1-63	M24×2	36	41.6	14
HC-N1-80	M30×2	46	53.1	18
HC-N1-100	M42×3	65	75	25