

HYDRAULIC CYLINDER FOR 7 MPa (HC) $\phi 125$ to $\phi 160$

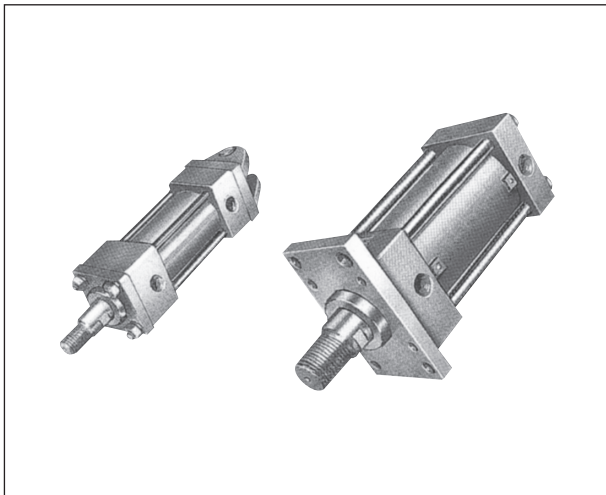

Features

1. The cylinder is highly wear resistant since the cylinder tube internal face is finished by precision honing and the piston rod is coated by hard chromium plating.
2. The packing is selected very carefully; packing with a long service life is used.
3. Five types of mounting (clevis type, foot mount type, head side flange mount type, rod side flange mount type and center trunnion type) are available and the type most suitable for the application can be selected.

JIS symbol

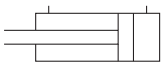

Description of the model designation

HC-DAX3-125×100- (A)

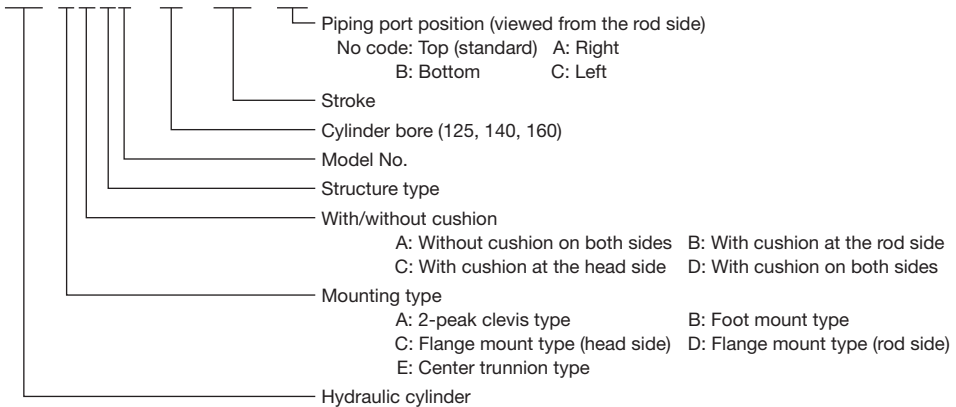

Specifications

Cylinder bore (mm)	Max. operating pressure (MPa)	Operating speed range (mm/s)	Operating temperature range (°C)	Rod diameter (mm)	Connection port (Rc)	Area (cm ²)		Cushion length (mm)		Max. stroke (mm)	
						Rod side	Head side	Rod side	Head side	Extension	Compression
125	7	8 to 300	-15 to 80	63	1	91.5	122.7	20	20	2,000	1,500
140				71	1	114.3	153.9	20	20	2,000	1,500
160				80	1	150.8	201.1	20	20	2,000	1,500

Outside dimensions

2-peak clevis type

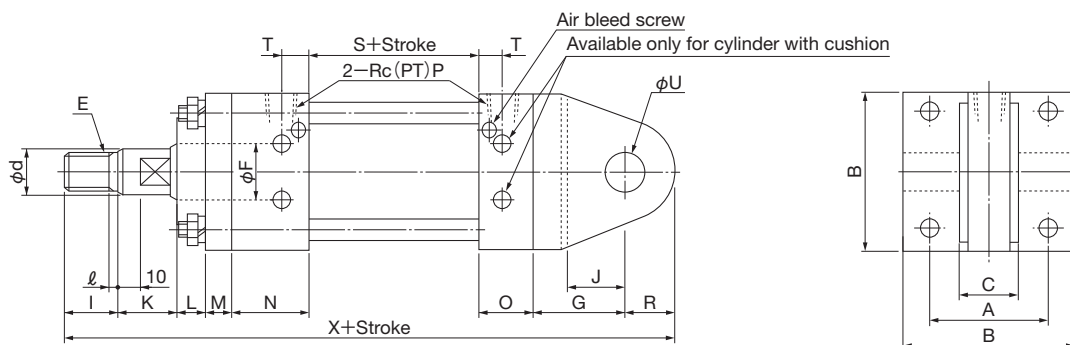

Note: Bracket pins are provided as standard.

Model	Cylinder bore	A	B	C	E		d		Rod Dia. F	G	I	J	K	L	M	N	O	P	R	S	T	U		ℓ	X
					Diameter	Pitch	Dimension	Tolerance														Dimension	Tolerance		
HC-A*X3-125x*	125	122	165	63	48	1.5	60	0 -0.030	63	98	70	63	40	15	24	64	49	1	50	122	24	50	$+0.1$ 0	6	532
HC-A*X3-140x*	140	138	185	80	55	2	68	0 -0.030	71	120	80	80	45	15	26	64	49	1	63	122	24	63	$+0.12$ 0	6	584
HC-A*X3-160x*	160	160	210	80	60	2	78	0 -0.030	80	125	90	90	50	15	31	64	49	1	75	142	24	71	$+0.12$ 0	6	641

■ Outside dimensions

Foot mount type

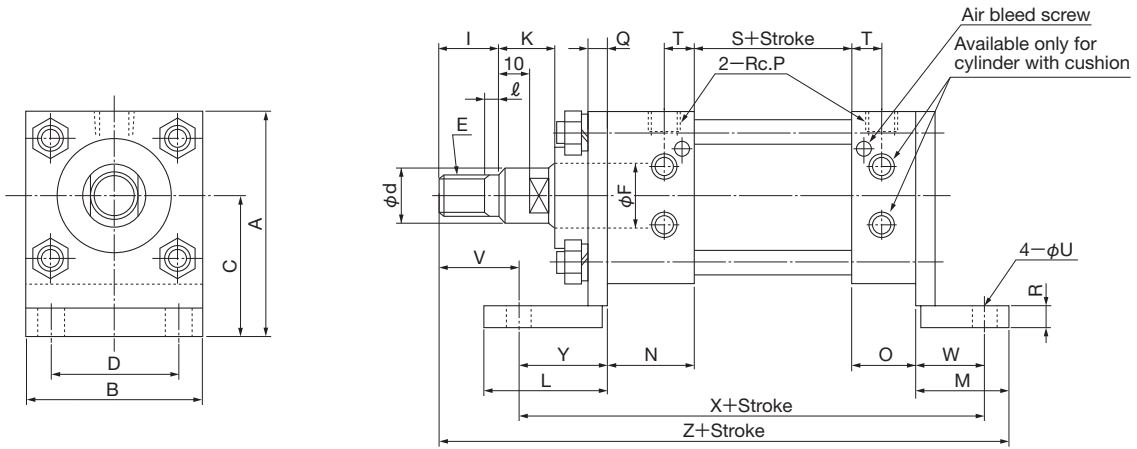

Model	Cylinder bore	A	B	C	D	E		d		Rod Dia. F	I	K	L	M	N	O	P	Q	R	S	T	U	V	W	X	Y	ℓ	Z
						Diameter	Pitch	Dimension	Tolerance																			
HC-B*X3-125x*	125	187.5	165	105	122	48	1.5	60	$0_{-0.030}$	63	70	40	119	95	64	49	1	24	15	122	24	24	59	66	391	90	6	479
HC-B*X3-140x*	140	207.5	185	115	138	55	2	68	$0_{-0.030}$	71	80	45	126	100	64	49	1	26	18	122	24	26	70	70	401	96	6	501
HC-B*X3-160x*	160	237	210	132	160	60	2	78	$0_{-0.030}$	80	90	50	141	110	64	49	1	31	18	142	24	31	80	75	436	106	6	551

Head side flange mount type

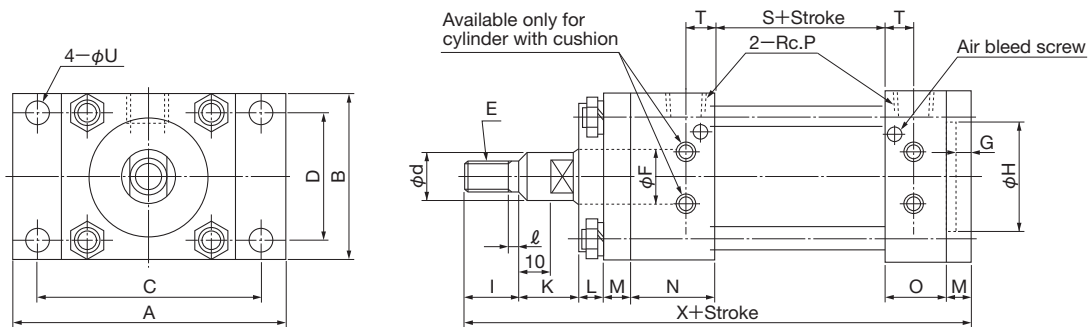

Model	Cylinder bore	A	B	C	D	E		d		Rod Dia. F	G	H (H8)		I	K	L	M	N	O	P	S	T	U	ℓ	X
						Diameter	Pitch	Dimension	Tolerance			Dimension	Tolerance												
HC-C*X3-125x*	125	272	175	224	132	48	1.5	60	$0_{-0.030}$	63	14	100	$+0.054_0$	70	40	15	24	64	49	1	122	24	24	6	408
HC-C*X3-140x*	140	300	195	250	145	55	2	68	$0_{-0.030}$	71	16	110	$+0.054_0$	80	45	15	26	64	49	1	122	24	26	6	427
HC-C*X3-160x*	160	335	218	280	165	60	2	78	$0_{-0.030}$	80	21	120	$+0.054_0$	90	50	15	31	64	49	1	142	24	31	6	472

■ Outside dimensions

Rod side flange mount type

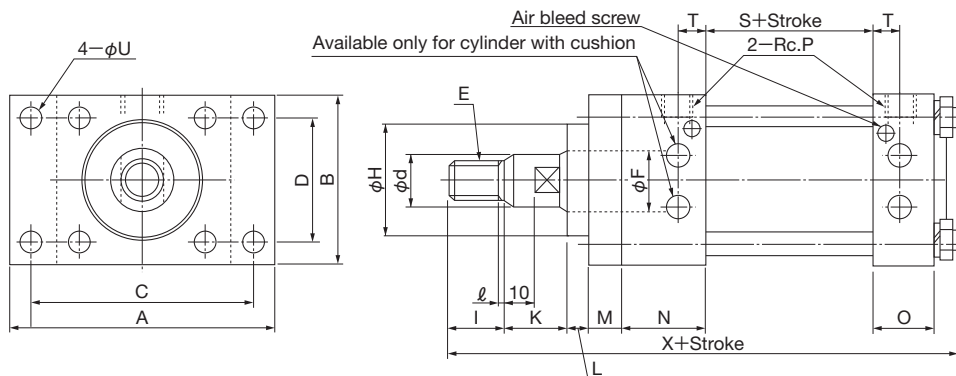

Model	Cylinder bore	A	B	C	D	E		d		Rod Dia. F	H (h8)		I	K	L	M	N	O	P	S	T	U	ℓ	Z
						Diameter	Pitch	Dimension	Tolerance		Dimension	Tolerance												
HC-D*X3-125x*	125	272	175	224	132	48	1.5	60	$0_{-0.030}$	63	100	$0_{-0.054}$	70	40	15	24	64	49	1	122	24	24	6	410
HC-D*X3-140x*	140	300	195	250	145	55	2	68	$0_{-0.030}$	71	110	$0_{-0.054}$	80	45	15	26	64	49	1	122	24	26	6	428
HC-D*X3-160x*	160	335	218	280	165	60	2	78	$0_{-0.030}$	80	120	$0_{-0.054}$	90	50	15	31	64	49	1	142	24	31	6	471

Center trunnion type

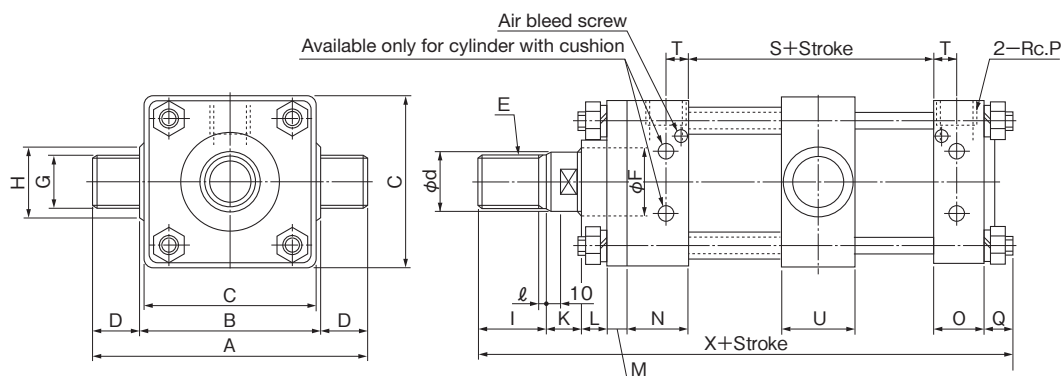

Note: The central position of the trunnion is $\frac{S+Stroke}{2}$

Model	Cylinder bore	A	B	C	D	E		d		Rod Dia. F	G (d9)		H	I	K	L	M	N	O	P	Q	S	T	U	ℓ	Z
						Diameter	Pitch	Dimension	Tolerance		Dimension	Tolerance														
HC-E*X3-125x*	125	274	170	170	50	48	1.5	60	$0_{-0.030}$	63	50	$0_{-0.142}$	60	70	40	15	24	64	49	1	27	122	24	64	6	411
HC-E*X3-140x*	140	322	196	192	63	55	2	68	$0_{-0.030}$	71	63	$0_{-0.174}$	73	80	45	15	26	64	49	1	27	122	24	76	6	428
HC-E*X3-160x*	160	358	216	212	71	60	2	78	$0_{-0.030}$	80	71	$0_{-0.174}$	81	90	50	15	31	64	49	1	30	142	24	85	6	471

Outside dimensions

Knuckle bracket

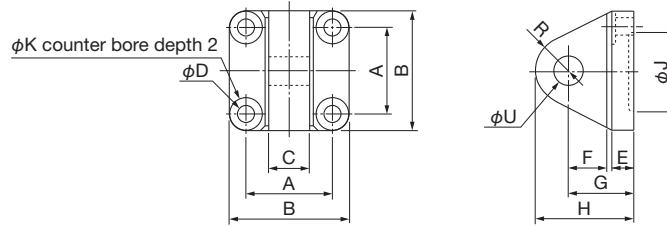

Model	A	B	C	D	E	F	G	H	J	K	R	U		Applicable cylinder type
												Dimension	Tolerance	
HC-A1-125	122	165	63	24	35	55	100	155	100	46	55	50	+0.100 0	φ125 clevis type
HC-A1-140	138	185	80	26	40	70	115	185	110	50	70	63	+0.120 0	φ140 clevis type
HC-A1-160	160	210	80	30	40	80	125	205	120	55	80	71	+0.120 0	φ160 clevis type

Knuckle

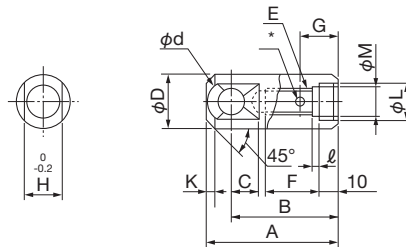

Note: *: Machined together with m6 tapping.

Model	A	B	C	D	d (H8)		E		F	G	H	K	L (H7)		M	ℓ	Applicable cylinder type
					Dimension	Tolerance	Diameter	Pitch					Dimension	Tolerance			
HC-B1-125	170	135	45	70	40	+0.039 0	48	1.5	75	50	52	15	60	+0.030 0	48.5	7	φ125 all type
HC-B1-140	200	155	55	80	45	+0.039 0	55	2	85	50	55	15	68	+0.030 0	55.5	7	φ140 all type
HC-B1-160	215	170	60	90	50	+0.039 0	60	2	95	50	58	18	78	+0.030 0	60.5	7	φ160 all type

Packing and o-ring list

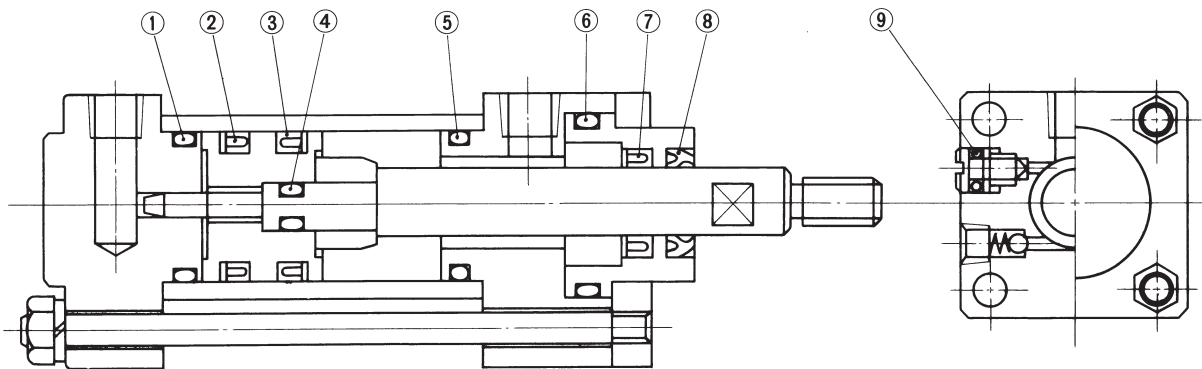

No.	Location where used	Cylinder bore	125	140	160
⑦	Rod seal		SKY-63	SKY-71	SKY-80
			1	←	←
②③	Piston seal		SKY-112	SKY-125	SKY-145
			2	←	←
⑧	Scraper		SDR-63	SDR-71	SDR-80
			1	←	←
①⑤	O-ring at cylinder tube		JIS B 2401-G120	JIS B 2401-G135	JIS B 2401-G150
			2	←	←
④	O-ring at piston		JIS B 2401-G40	JIS B 2401-G45	JIS B 2401-G55
			1	←	←
⑥	O-ring at gland		JIS B 2401-G105	JIS B 2401-G115	JIS B 2401-G125
			1	←	←
⑨	O-ring at cushion valve		JIS B 2401-P10A	JIS B 2401-P10A	JIS B 2401-P10A
			— *	←	←

NOTE: *: 2 pcs. for a cylinder with a cushion at both sides, 1 pc. for a cylinder with a cushion at one side, and not used for cylinders without cushions.