

# TYPE T1 SUBPLATE FOR SOLENOID VALVE

## Outside dimensions

SHD025-02T1A

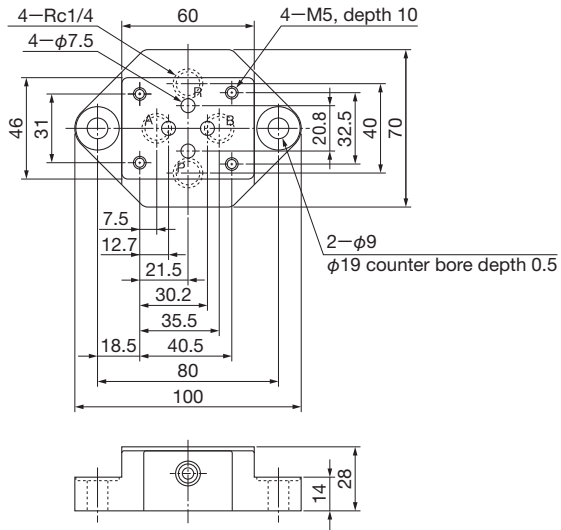

Mass: 1.0kg

SHD025-03T1A

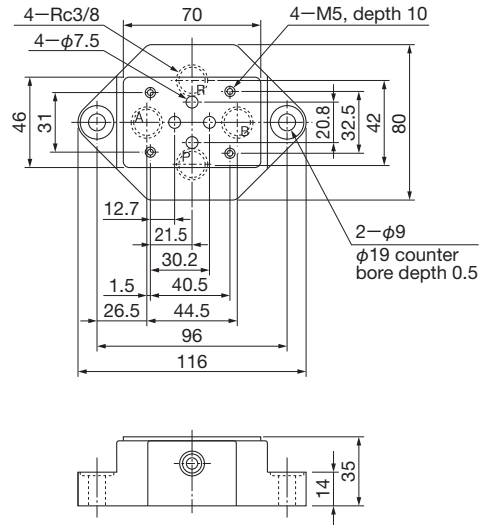

Mass: 1.6kg

SHD03-04T1A

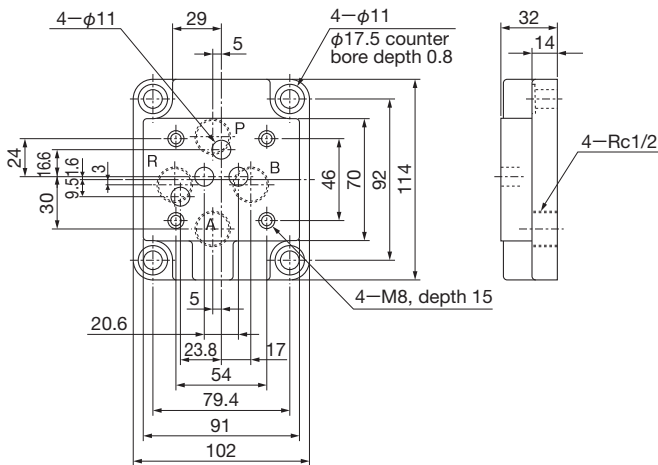

Mass: 1.9kg

SHD03-06T1A

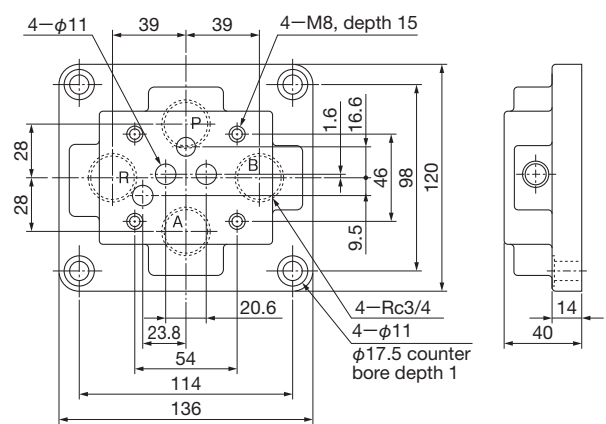

Mass: 2.6kg

Outside dimensions

SHD04-04T1

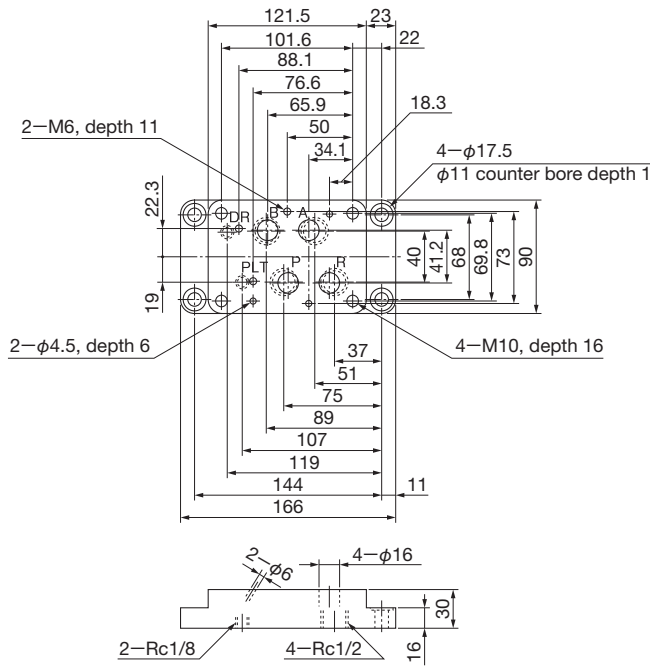

Mass: 2.4kg

SHD04-06T1

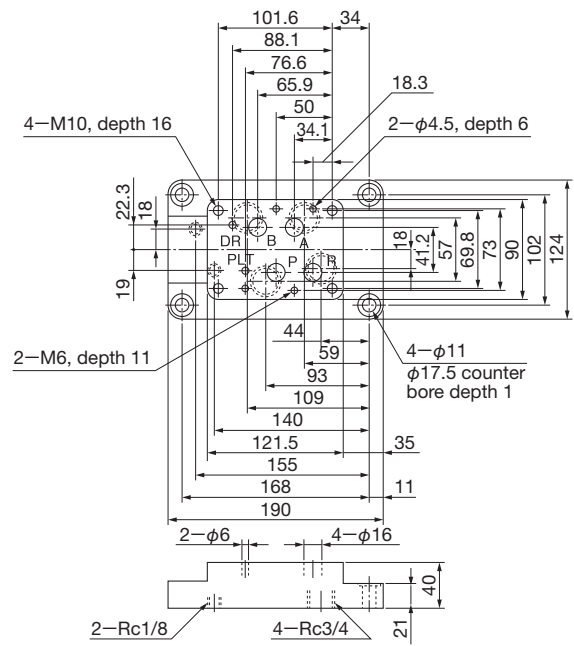

Mass: 4.5kg

SHD06-\*\*T1 (A)

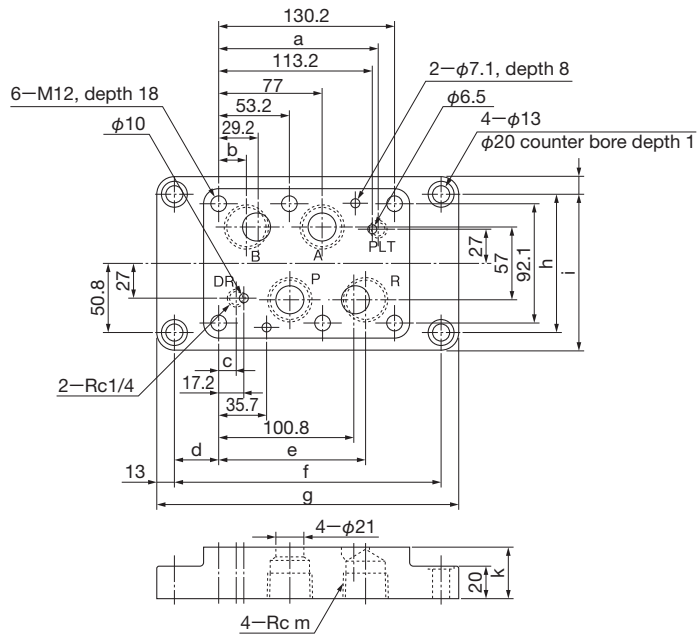

Mass: SHD06-06T1A 4.8kg  
SHD06-08T1 6kg

Dimension table of SHD06-\*\*T1(A)

(Unit: mm)

Model	a	b	c	d	e	f	g	h	j	k	m
SHD06-06T1A	116	27	14.5	24.43	103	179	205	80	114	35	3/4
SHD06-08T1	117	21.5	13.5	33.9	109	198	224	108	134	40	1

## TYPE T3 SUBPLATE FOR RELIEF VALVE

### Outside dimensions

Type 3 subplate has larger pitches compared with T1 subplate to facilitate retightening.

SHR04-\*\*-T3

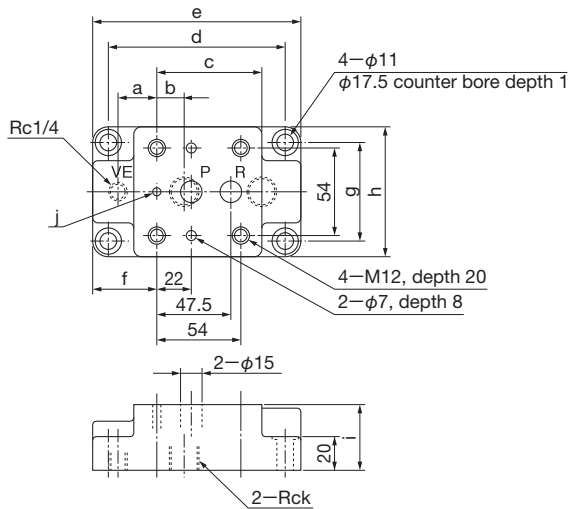

SHR06-\*\*-T3

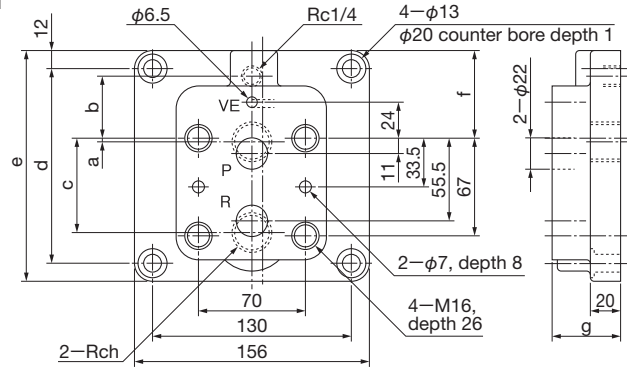

(Unit: mm)

(Unit: mm)

Model	a	b	c	d	e	f	g	h	i	j	k
SHR04-04T3	24.5	17.5	67.5	114	132	40	62	80	40	φ6	1/2
SHR04-06T3	28	22	85	145	165	48	71	91	45	φ6	3/4

Model	a	b	c	d	e	f	g	h
SHR06-06T3	2	41	65	132	156	59	45	3/4
SHR06-08T3	11	54	88	176	200	75	55	1

## TYPE T3 SUBPLATE FOR PRESSURE REDUCING VALVE

### Outside dimensions

SHG02-02T3

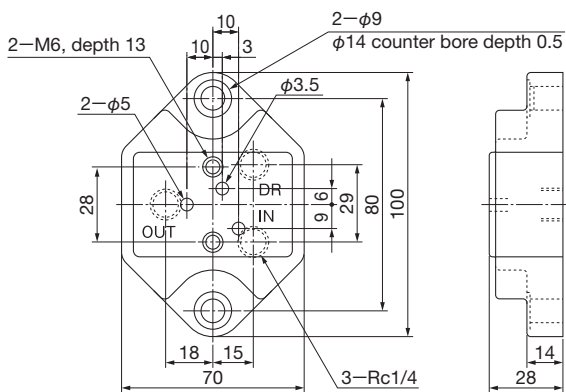

SHG03-03T3

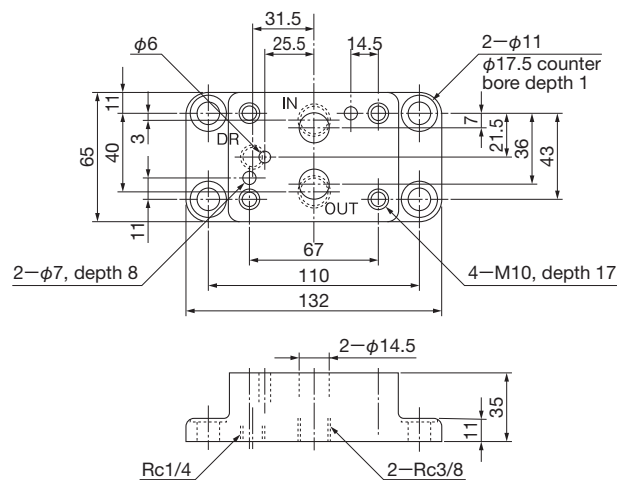

# TYPE T3 SUBPLATE FOR PRESSURE REDUCING VALVE

## Outside dimensions

SHG03-04T3

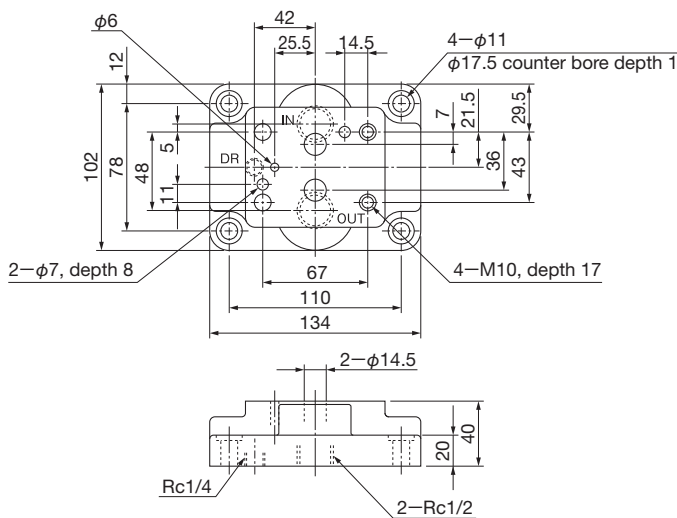

SHG06-\*\*T3

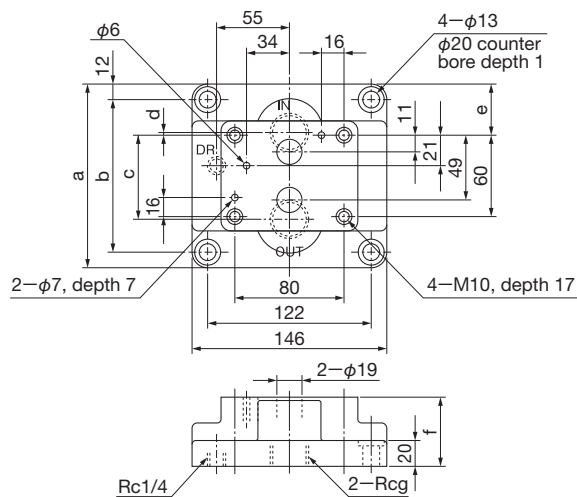

(Unit: mm)

Model	a	b	c	d	e	f	g
SHG06-06T3	134	110	62.5	2.5	37	50	3/4
SHG06-08T3	154	130	70	10	47	57	1

# TYPE T3 SUBPLATE FOR SEQUENCE VALVE

## Outside dimensions

SHQ02-02T3

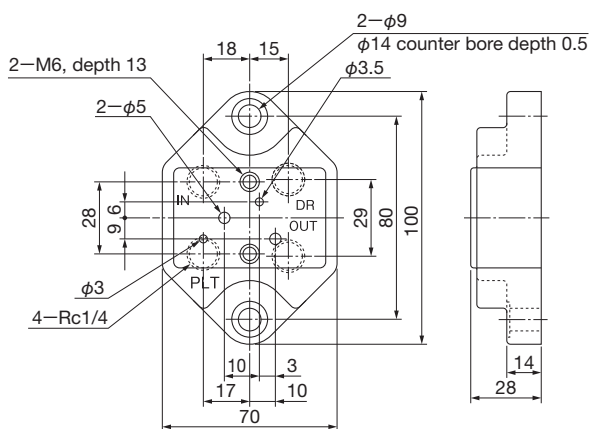

SHQ03-03T3

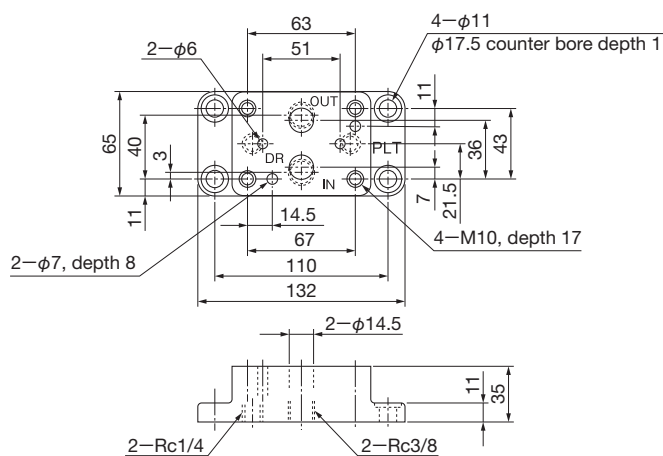

SHQ03-04T3

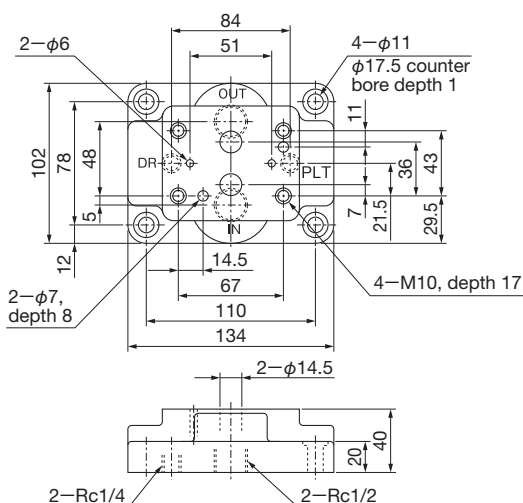

SHQ06-\*\*T3

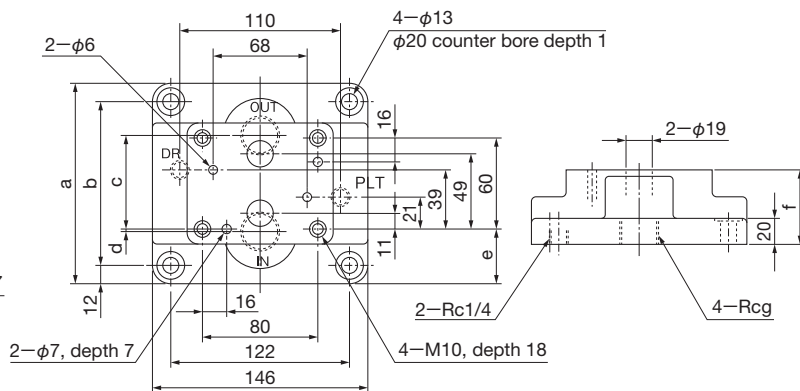

(Unit: mm)

Model	a	b	c	d	e	f	g
SHQ06-06T3	134	110	62.5	2.5	37	50	3/4
SHQ06-08T3	154	130	70	10	47	57	1

# TYPE T3 SUBPLATE FOR SOLENOID VALVE

## Outside dimensions

SHD025-02T3A

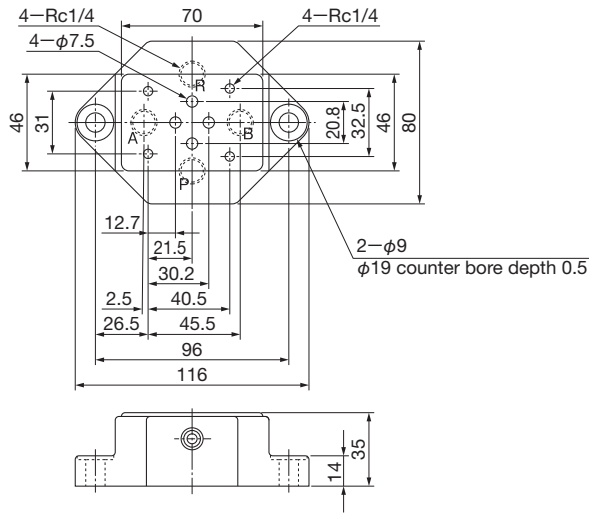

SHD025-03T3A

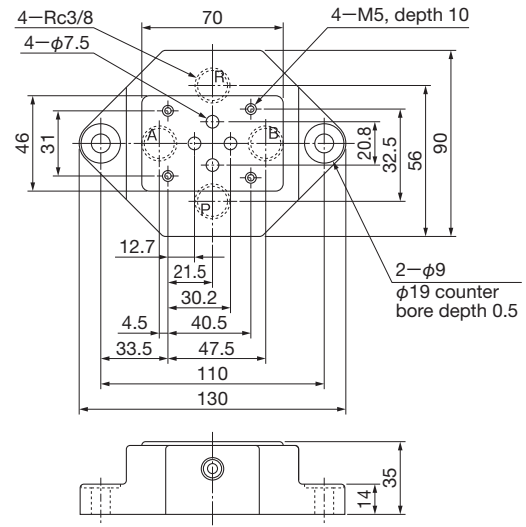

SHD03-\*\*T3

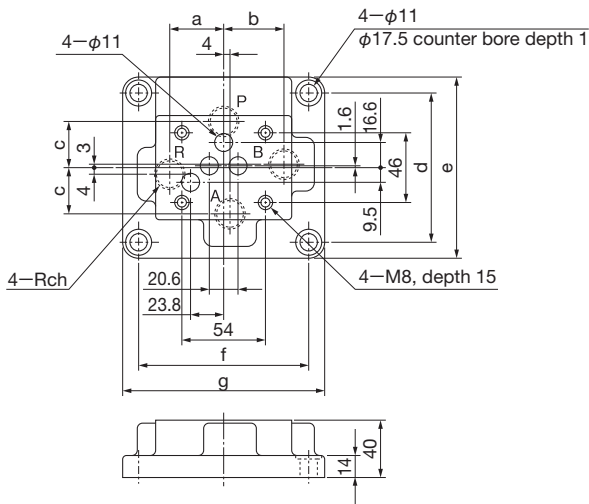

(Unit: mm)

Model	a	b	c	d	e	f	g	h
SHD03-04T3	37	40	31	98	120	114	135	1/2
SHD03-06T3	48	51	42	126	148	142	164	3/4

# TYPE T3 SUBPLATE FOR SOLENOID VALVE

## Outside dimensions

SHD04-04T3

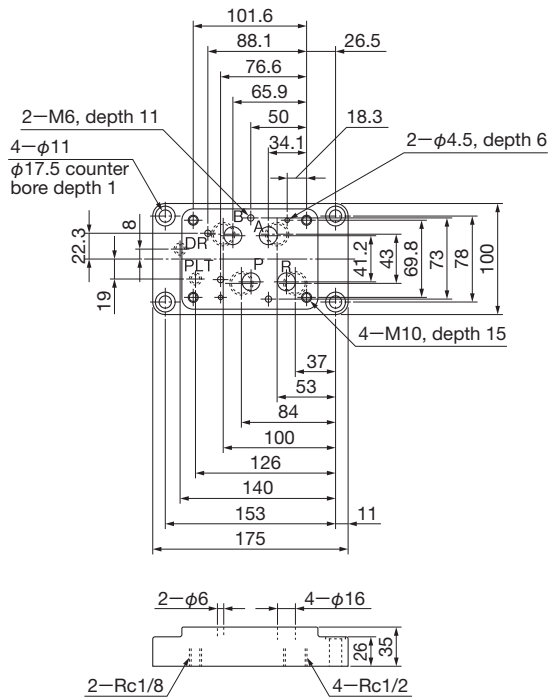

SHD04-06T3

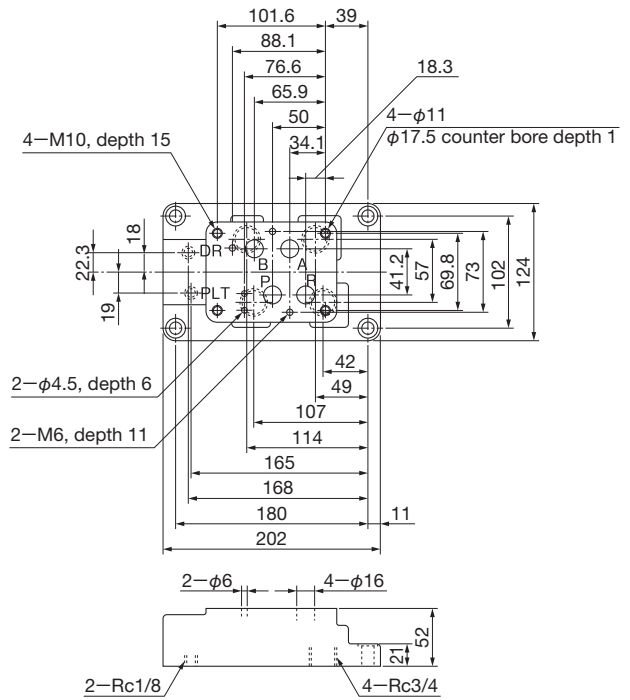

SHD06-\*\*T3

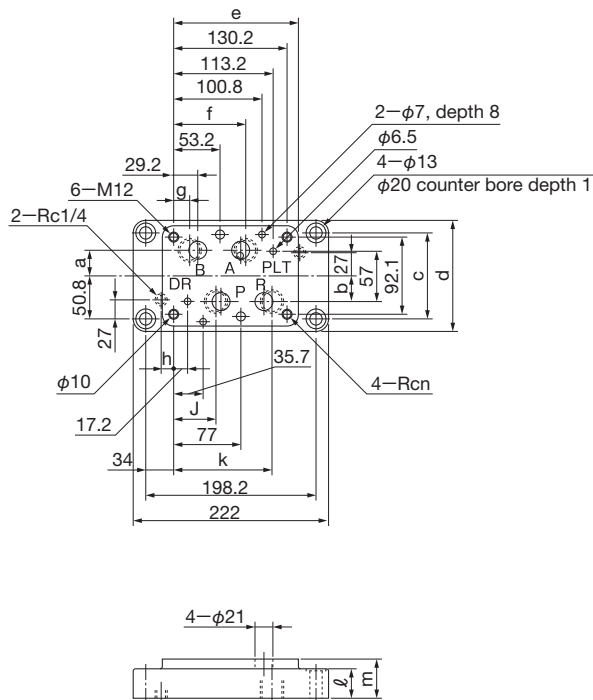

(Unit: mm)

Model	a	b	c	d	e	f	g	h	J	k	l	m	n
SHD06-06T3	28.5	28.5	100	124	142.2	82.2	19.2	12	48.2	111.2	31	45	3/4
SHD06-08T3	20	20	110	134	146.2	83.2	6.2	16	47.2	124.2	31	50	1