

■Description of the model designation

WVP-VD1-G30-SW-B

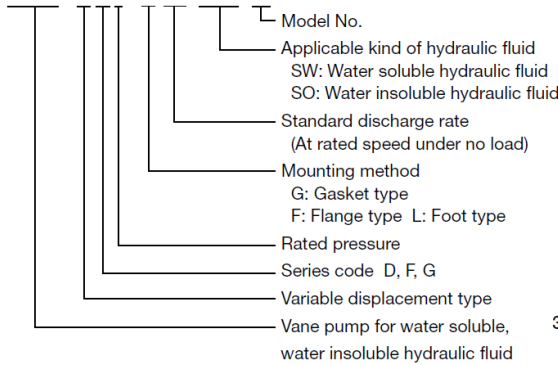

This vane pump for coolant is adapted to high-pressure machining.

■Features

1. Long life and high performance
2. Since the pump is a variable-displacement type, no relief valve is necessary.
3. Available in a series so that the discharge rate most suitable to the application can be selected.
4. Can be mounted in the same dimensions as conventional hydraulic pumps.

⚠ Cautions on use Please read the Operating Manual carefully to ensure correct usage.

Pump selection: The pump characteristics differ depending on the operating conditions such as the fluid used, the dead head setting pressure and the circuit. Therefore, it is necessary to select a pump that has sufficient margin.

■Handling

1. Installation

Basically, pumps of this series is installed in the same manner as the HVP-V*1 series variable displacement vane pumps. The pump inlet port must be at the same level or lower than the fluid surface level and the suction filter and the strainer position must not be more than 200 mm lower than the bottom or reservoir.

For a drain pipe, use a pipe larger than the pump drain port diameter and the drain pipe end must be into the fluid.

2. Removal of chips

When designing a reservoir, ensure that it will be possible to remove chips from the fluid. Chips of 50µm or larger should be removed before the fluid is taken into the suction side of pump.

Chip Management Standard

Coolant Kind Workpiece	Operating pressure (MPa)	Contamination Level (mg/L)	Contamination Particle dia. (µm)	Workpiece Material
Water soluble	3 or less	500 or less	50 or less	Aluminum (A L) Iron (Fe)
	3 to 4	250 or less		
Water insoluble hydraulic fluid	4 or less	500 or less		
	7 or less	250 or less		

3. Coolant

The kind of coolant and recommended brands of coolant that can be used with WVP-V*1 series are indicated below.

Coolant Kind Workpiece	Operating pressure MPa	Dilution Ratio	Recommended Kind of Fluid and Brand		Fluid Temperature °C
Water soluble	3 or less	50 or less	JIS K 2241	Class 1 Type 1 to Type 2 Class 2 Type 1	5 to 50
	3 to 4	25 or less			
Water insoluble hydraulic fluid	4 or less	—	JIS K 2241	Class 1 Type 1 to Type 4 Class 2 Type 1 to Type 4	
	7 or less	—			

4. Maintenance

- Checking the suction filter and strainer
Install a vacuum gauge at the pump inlet port to prevent cavitation and prolong pump life. If the vacuum gauge indicates 150 mmHg or higher, check the suction filter and the strainer and wash them to remove deposits. Use a strainer with a filtering capacity of 150 mesh or better.
NOTE: Dilute the coolant as specified in the table above.
- Checking the water-soluble coolant
When water-soluble coolant is used, check the coolant to avoid degradation of rust-prevention performance and bacterial decay
Degraded rust prevention performance can cause rusting in the pump, which leads to low pump performance and short pump life. Development of bacteria will cause clogging of the suction filter and the strainer as well as corrosion of the pump component parts.

■Specifications

Model	Discharge rate under no load (L/min)		Max. operating pressure (MPa)		Pressure adjustment range (MPa)		Revolving speed (min ⁻¹)	
	1,000 min ⁻¹	1,200 min ⁻¹	SO	SW	SO	SW	Max.	Lowest
WVP-VD1-G30-*--B	25	30	7	4	3 to 7	2 to 4	1,200	750
WVP-VD1-F30-*--B								
WVP-VF1-L56-*--B								
WVP-VF1-L90-*--B								
WVP-VF1-L120-*--B								
WVP-VG1-G160-*--B	13	13	4	4	3 to 7	2 to 4	1,200	750

(Note) 1. The pressure adjustment range means the same at the dead head. Direction of rotation is to right viewed from the shaft end.

2. Symbol "*" in the model designation indicates SO for use of water-insoluble cutting fluid or SW for use of water-soluble cutting fluid.

Outside dimensions

WVP-VD1-G30-*-B

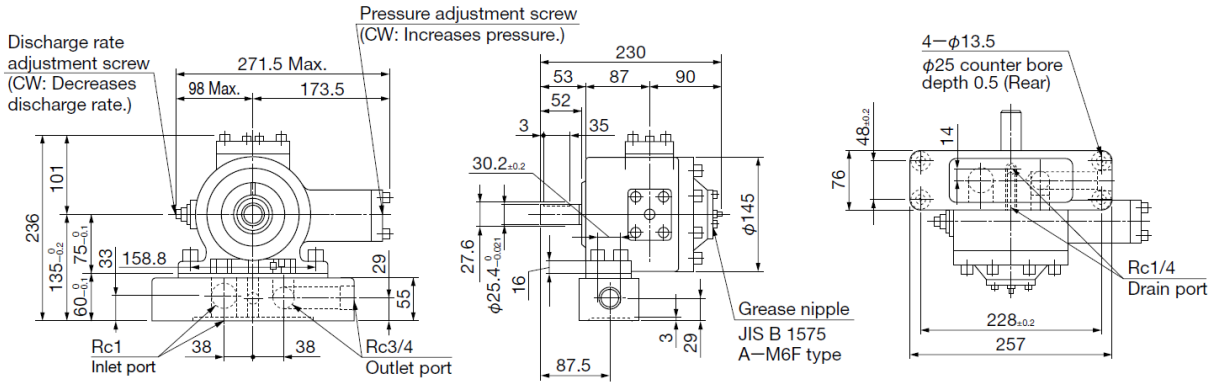

Mass: 27kg

WVP-VF1-L-*-B

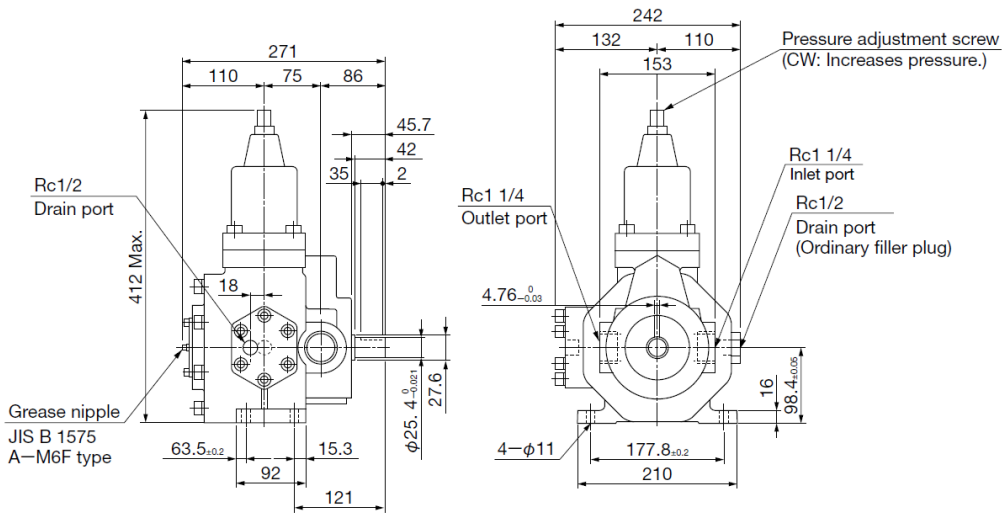

Mass: 48kg

WVP-VG1-G160-*-B

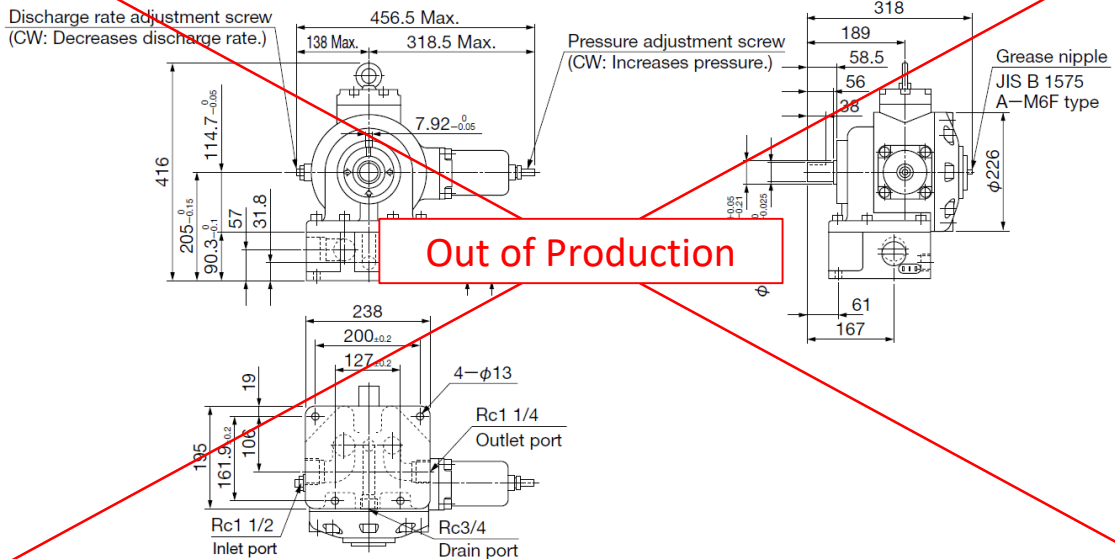

Mass: 86kg

Characteristics

For water insoluble hydraulic fluid (Conditions: Temp. 30°C, viscosity 10.7 mm²/s)

WVP-VD1-G30-SO-B

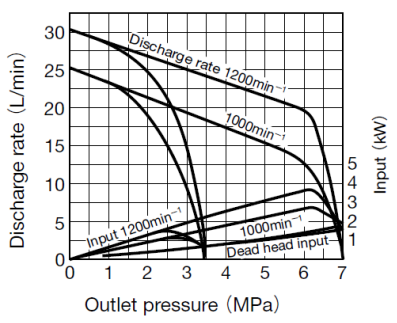

WVP-VF1-L56-SO-B

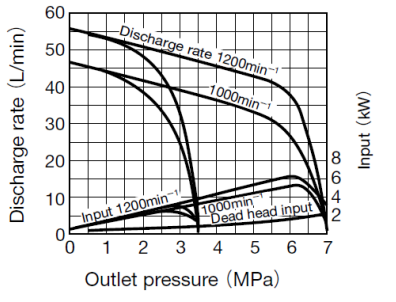

WVP-VF1-L90-SO-B

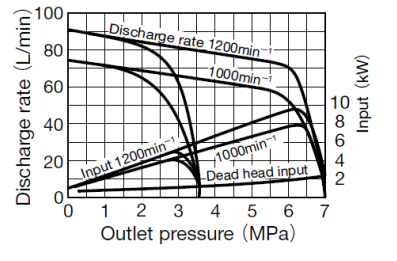

WVP-VF1-L120-SO-B

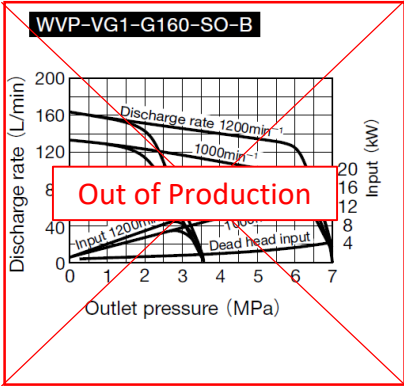
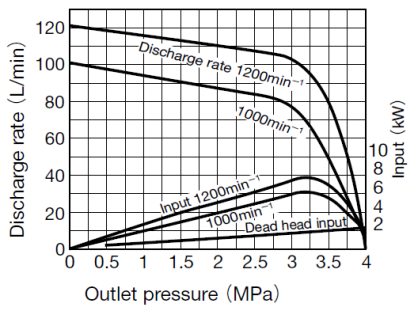

For water-soluble cutting fluid (Conditions: Temp. 30°C, viscosity 0.9 mm²/s, cutting fluid Class A1, No. 2, fiftyfold dilution)

WVP-VD1-G30-SW-B

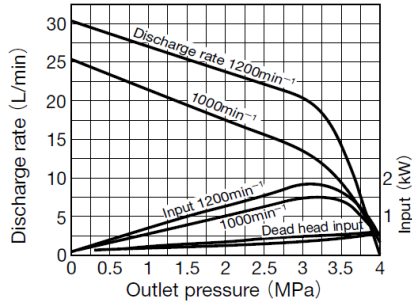

WVP-VF1-L56-SW-B

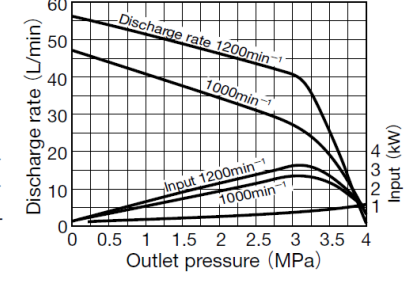

WVP-VF1-L90-SW-B

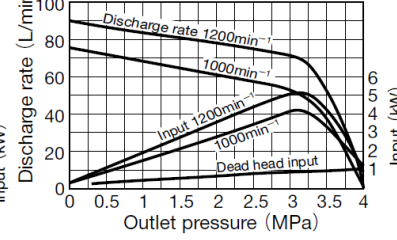

WVP-VF1-L120-SW-B

